

MOTOR SPECIFICATION SHEET

MODEL : SF-QR 3HP 4P IP44 (LT)

USED FOR : STANDARD

| DESCRIPTION | DETAIL | | | |
|----------------------------------|--|------|------|--|
| PHASE | 3 | | | |
| MODEL NAME | SF-QR | | | |
| RATED OUTPUT, HP (kW) | 3 (2.2) | | | |
| POLE | 4 | | | |
| CODE | MEATH CODE : 1M002F-400220QRGC0 | | | |
| OUTLINE DRAWING NO. | ONM04O199-C | | | |
| RATED VOLTAGE (V) | 220 | 380 | 415 | |
| RATED FREQUENCY (Hz) | 50 | 50 | 50 | |
| RATED CURRENT (A) | 8.7 | 5.0 | 4.9 | |
| RATED SPEED (min ⁻¹) | 1420 | 1420 | 1440 | |
| RATED EFFICIENCY (%) | 79.7 | 79.7 | 79.7 | |
| EFFICIENCY CLASS | IE1 | | | |
| THERMAL CLASS | 155(F) | | | |
| RATING | S1 (CONTINUOUS) | | | |
| ENCLOSURE CONSTRUCTION | TOTALLY ENCLOSED FAN COOLED | | | |
| DEGREES OF PROTECTION | IP44 | | | |
| METHOD OF COOLING | IC411 | | | |
| FRAME NO. | 100L | | | |
| WEIGHT (kg) | 24 | | | |
| STANDARD | IEC 60034-1, IEC 60034-30-1 | | | |
| INSTALLATION | FOOT MOUNTED | | | |
| ROTATION | CCW (VIEWED FROM SHAFT END) | | | |
| BEARING | LOAD SIDE : 6206ZZ | | | |
| | OPPOSITE SIDE : 6205ZZ | | | |
| BEARING GREASE | UREA GREASE | | | |
| NOISE (dB.A) | 68 | | | |
| VIBRATION | V10 | | | |
| CIRCUMSTANCE CONDITION | AMBIENT TEMPERATURE : -20 ~ +40°C | | | |
| | AMBIENT HUMIDITY : 95%RH OR LESS | | | |
| | ABOVE SEA LEVEL : 1000m OR LESS | | | |
| | ENVIRONMENT : NO BURSTING/EROSIVE GAS OR VAPOR | | | |
| COLOR | MUNSELL N1.5 (BLACK) | | | |
| TERMINAL BOX | NO. OF LEAD WIRES : 6 | | | |
| | SOURCE CONNECTION : TERMINAL BLOCK | | | |
| SHAFT SWING | ≤0.03mm | | | |
| MATERIAL | FRAME : STEEL PLATE | | | |
| | BRACKET : ALUMINIUM | | | |
| | SHAFT : CARBON STEEL | | | |
| | STATOR CORE : ELECTRICAL STEEL | | | |
| | WIRE : ENAMELLED COPPER MAGNET WIRE | | | |
| | ROTOR CORE : ELECTRICAL STEEL | | | |
| | CONDUCTOR : ALUMINIUM | | | |
| | TERMINAL BOX : STEEL PLATE | | | |
| PAINTING | PAINTING : ALKYD-NITROCELLULOSE RESIN | | | |
| | PRODUCTION COUNTRY : THAILAND | | | |

Specifications subject to change without notice.

| | | | | |
|--------------------------------|--|--|--|--|
| SPECIFICATION SHEET NO. | | | | |
| SS-N-0020-A | | | | |

MODEL SF-QR THREE PHASE INDUCTION MOTOR OUTLINE DRAWING

TOTALLY ENCLOSED FAN COOLED TYPE
DEGREES OF PROTECTION IP44

CUSTOMER _____
USER _____
FOR _____
CUSTOMER'S ORDER NO. _____
QUANTITY _____
MFG. ORDER NO. _____

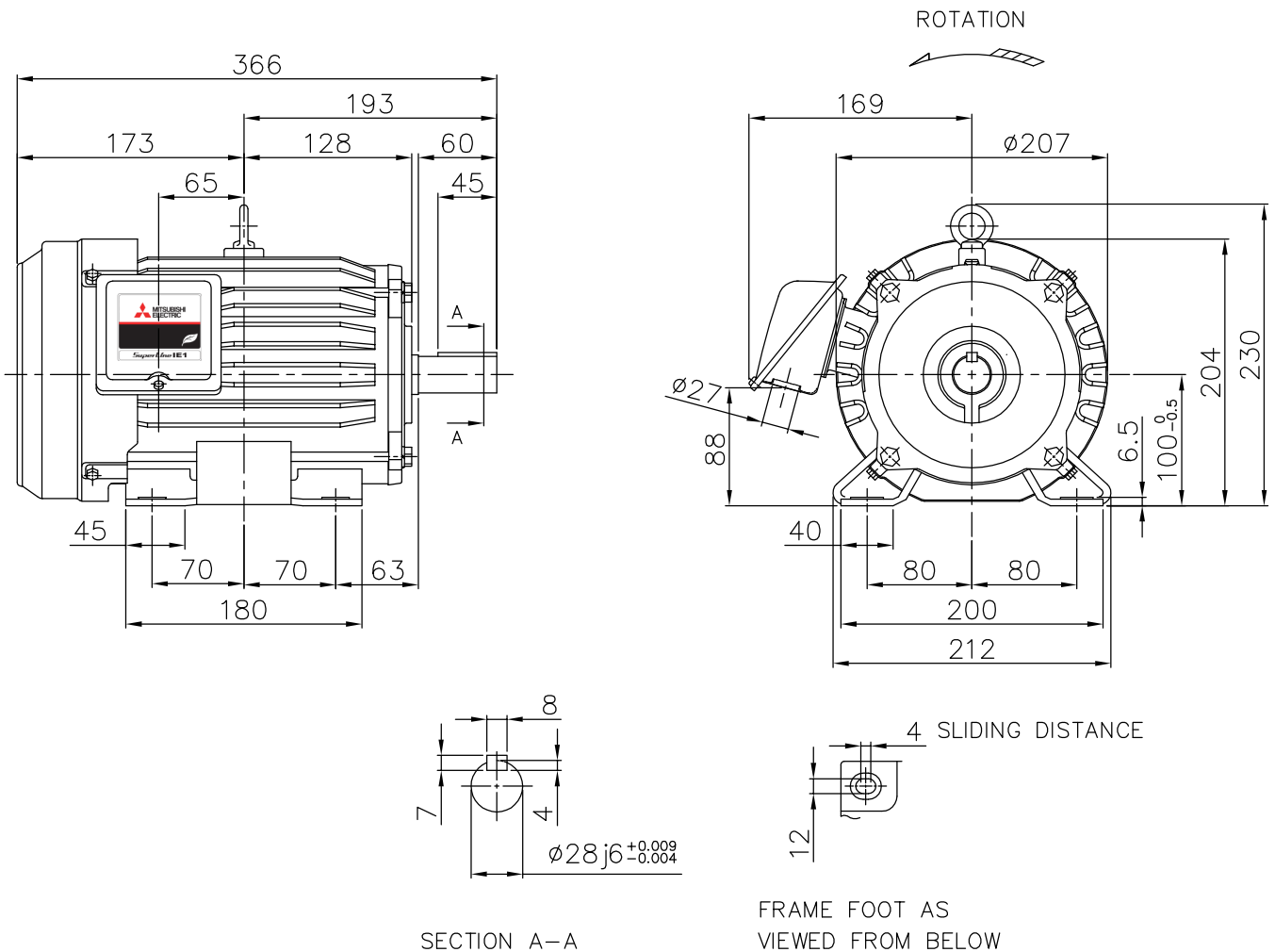

| YOUR ORDER | FRAME SIZE | RATING | TH. CLASS | AMB. TEMP. | BEARINGS | | COLOR | DIRECTION OF ROTATION (VIEWED FROM SHAFT END) | NO. OF LEAD WIRES | REMARKS |
|------------|------------|------------|-----------|------------|-----------|-----------|----------------------|---|-------------------|---------|
| | | | | | LOAD SIDE | OPP. SIDE | | | | |
| | 100L | S1 (CONT.) | 155(F) | 40°C | 6206ZZ | 6205ZZ | BLACK (MUNSELL N1.5) | CCW | 6 | |

| YOUR ORDER | OUTPUT | | POLES | VOLTS | HERTZ | AMP. | RPM | IE CODE-RATED EFF. | REMARKS |
|------------|--------|-----|-------|-------------|-------|-------------|----------------|--------------------------|---------|
| | HP | KW | | | | | | | |
| | 3 | 2.2 | 4 | 220/380/415 | 50 | 8.7/5.0/4.9 | 1420/1420/1440 | IE1 79.7%/79.7%/79.7% | LT |
| | 2 | 1.5 | 6 | 220/380/415 | 50 | 7.4/4.3/4.5 | 940/940/940 | IE1 76.4%/76.4%/76.1% | LT |

MITSUBISHI ELECTRIC AUTOMATION(THAILAND)CO.,LTD

| | | | |
|--|---------------------------------|---------------------|------|
| | | OUTLINE DRAWING NO. | REV. |
| | DIMENSION IN mm. SCALE : NTS | 0 N M 0 4 0 1 9 9 C | |